

JOB NAME \_\_\_\_\_ SERIAL NUMBER \_\_\_\_\_



# Arctic®

WALK-IN COOLERS & FREEZERS

## Walk-In Installation, Operation, Maintenance & Warranty Manual

**IMPORTANT**



**WARRANTY  
REGISTRATION  
REQUIRED!  
SEE PAGE 24.**

**Manufactured By:  
Arctic Industries, LLC.**

Miami, FL  
(305) 883-5581

Los Angeles, CA  
(626) 508-0920



**Intertek**  
CONFORMS TO  
NSF STD 7



**Intertek**  
CONFORMS TO  
UL STD 471

# TABLE OF CONTENTS

SECTION 1: GENERAL INFORMATION.....	2
1.1 INTRODUCTION.....	2
1.2 INSPECTION .....	2
1.3 HANDLING OF PANELS .....	2
SECTION 2: INSTALLATION .....	3
2.1 INSTALLATION PROCEDURE .....	3
2.2 FLOOR PANELS.....	5
2.3 FLOORLESS WALK-INS .....	6
2.3.1 Coolers .....	6
2.3.2 Freezers .....	6
2.3.3 Combinations .....	7
2.3 WALL PANELS .....	7
2.4 DOOR PANELS .....	8
2.5 CEILING PANELS.....	10
2.7 OUTDOOR INSTALLATION.....	11
2.7.1 Roof Covers .....	11
2.7.2 Door caps .....	13
2.7.3 Box-to-Slab Attachment .....	13
2.7.4 Snow / Ice Load.....	13
2.8 DIAMOND TREAD PLATE INSTALLATION.....	13
2.8.1 Wall Panels.....	13
2.8.2 Floor Panels .....	14
2.9 COMPLETING THE INSTALLATION .....	14
2.9.1 By Installer.....	14
2.9.2 By Electrical Contractor.....	15
2.9.3 By Refrigeration Contractor.....	16
2.9.4 Compressor and walk-in Warranty Card .....	17
2.9.5 Thermometer Adjustment.....	17
SECTION 3: MAINTENANCE .....	18
3.1 CLEANING .....	18
3.2 DOOR HARWARE .....	18
3.3 CEILING.....	18
SECTION 4: SERVICE .....	19
4.1 DOOR CLOSER.....	19
4.2 HEATER DOOR REPLACEMENT.....	20
4.3 DOOR SWEEP REPLACEMENT .....	21
4.4 MAGNETIC GASKET REPLACEMENT .....	22
4.5 THERMOSTAT ADJUSTMENTS .....	22
SECTION 5: ELECTRICAL SCHEMATICS .....	23
SECTION 6: REPLACEMENT PARTS .....	23
SECTION 7: WARRANTY.....	24

# SECTION 1: GENERAL INFORMATION

## 1.1 INTRODUCTION

These instructions have been prepared to assist you with the erection and maintenance of your Arctic Walk-In Cooler/Freezer.

A single set of instructions can scarcely cover all situations; however, the following procedures apply to most installations and can be used as guidelines in all.

Your walk-in has been pre-assembled at the factory to ensure proper match and fit of all panels. Each panel has been labeled with the appropriate number designation for walls, doors, floors and ceilings. All panels are pre-gasketed at the factory. A layout drawing is provided to assist the installer in the assembly of the unit.

We suggest that you read and become familiar with these instructions before proceeding with the installation.

## 1.2 INSPECTION

The panels and optional equipment were inspected at the factory before shipment; however, freight damage or shortages can occur. Count and inspect your shipment carefully and describe on the delivery ticket any shortages or damage to cartons/pallets or contents before signing for the shipment. In the event that concealed damage is discovered after receipt of goods, save all packaging materials. **REMEMBER, IF SHIPMENT IS PRE-PAID ARCTIC FILES THE CLAIM AND IF FREIGHT IS THIRD PARTY THE CUSTOMER FILES THE CLAIM AND ARCTIC ASSISTS.**

## 1.3 HANDLING OF PANELS

Damage to the panel sections and accessories can occur if they are not handled properly during unloading or set-up. To minimize risk of damage, observe the following precautions:

1. Stack panels on a platform or protective material to avoid contact with ground moisture.
2. Protect panels from direct contact with any rough surface
3. Avoid resting panels on their corners or edges and keep panels flat to prevent denting.
4. When handling panels over 12' long, hold panels vertically. If panels are to be handled flat the center section must be supported with additional manpower.
5. If panels must be kept in outdoor storage, cover them carefully with plastic sheeting or tarpaulin. Panels in contact with other panels, other metals, or some packaging materials in the presence of moisture can become permanently stained.

# SECTION 2: INSTALLATION

## 2.1 INSTALLATION PROCEDURE

A review of the layout drawing which accompanies your walk-in, will guide you in establishing where each panel goes. Segregate the different types of floor panels: floor, ceiling, wall and partition. This simple procedure will minimize handling and save labor. See Fig. 1 & 2.

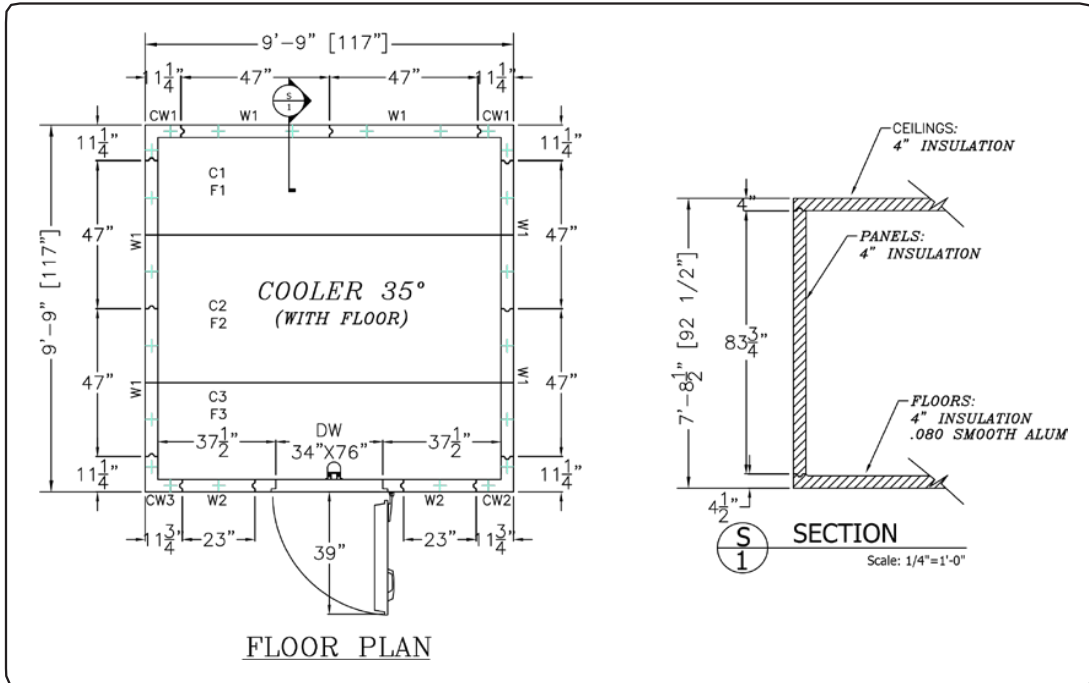

FIG 1. LAYOUT DRAWING

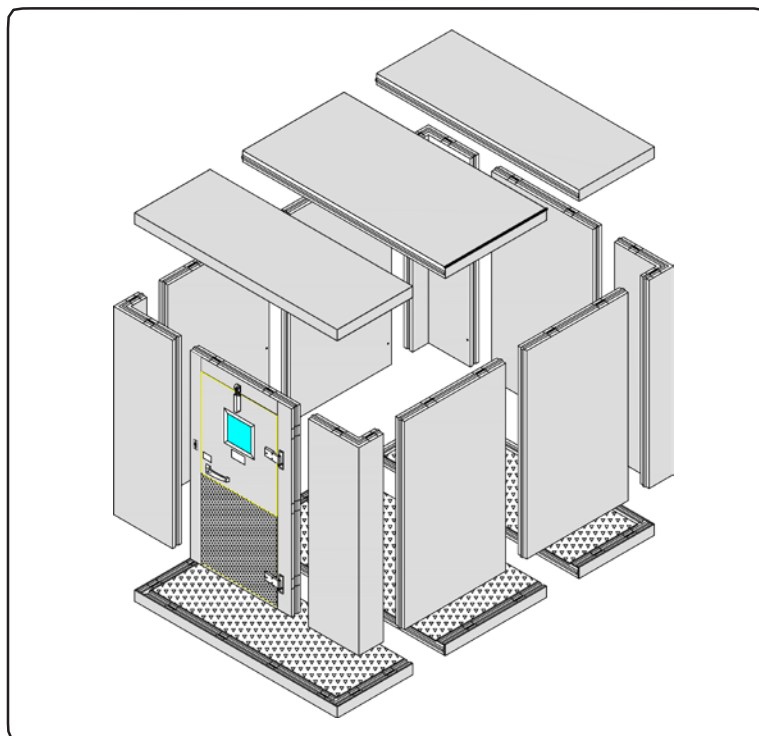

FIG 2. TYPES OF PANELS

Make sure that the walk-in area is free of debris and swept clean. A clear site will reveal any major surface unevenness and any irregularities on the adjacent building walls. For ease of installation, tight panel seams, and proper door operation, **the site floor or slab must be absolutely flat and level.**

A minimum 2" clearance or "breathing space" should be allowed between the walk-in and adjacent walls. This clearance is necessary for air circulation to prevent moisture condensation, and to allow for any variation in building walls which may not be square or plumb. This clearance may not be practical when an outdoor walk-in is against an exterior building wall and the walk-in roof cover must be flashed up to the building wall.

Pay particular attention to the location of self-contained top or side mount refrigeration units which must have sufficient space for service access and proper air circulation. Follow the instructions and clearance recommendations provided with the refrigeration unit.

Next, chalk the perimeter outline of the structure and confirm its squareness by making diagonal measurements. If the corner angles are square, you are ready to start installation. See Fig. 3.

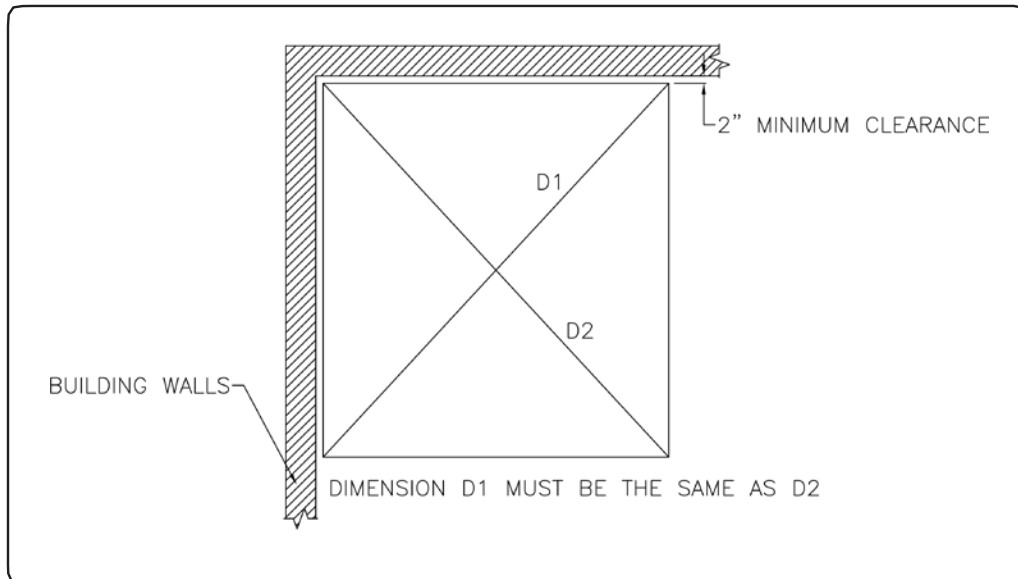

**FIG 3. SITE LAYOUT**

Take time to familiarize yourself with the construction of the panels and their interlocking mechanism.

All Arctic panels have tongue (male) and groove (female) perimeter edges. This interlocking design, along with the factory-installed edge gasket will result in an air-tight structure if installed square and level.

All panels are equipped with locking devices set into aligned positions along the perimeter. The male cam locks (with arm) are located in the tongue; the female locks (with pin) are located in the groove. Access to locking mechanism (male cam lock) is provided through a hole on the interior side of the panels. See Fig. 4.

The hardware package includes an L-shaped 5/16" hex wrench. Insert the hex wrench into the hole in the panel and engage it firmly in the opening of the locking arm. **FIRST TURN THE WRENCH COUNTER-CLOCKWISE TO CHECK THAT THE LOCKING ARM IS BROUGHT TO A COMPLETELY OPEN POSITION BEFORE JOINING PANELS.** To lock, turn the wrench clockwise approximately 75 degrees to engage arm with pin. Cam action of the lock will pull the panels together, compressing their gaskets and providing an airtight seal.

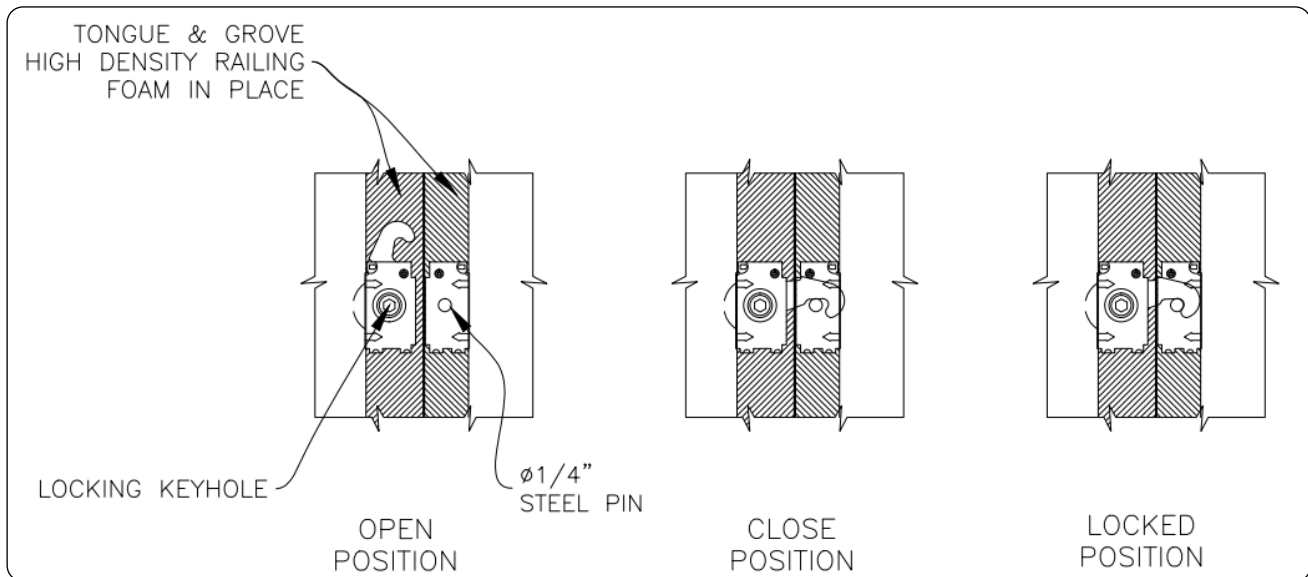

**FIG 4. CAM-LOCK DETAIL**

Now, check the installation drawing and study the general layout and specific panel location. All panels are labeled on their inside face to match the layout drawing and to show their proper orientation (arrows on wall panels point up). The job number marked on the panel edge identifies all panels for a particular job. For jobs, with more than one walk-in, the job number will have a letter suffix to identify which panels correspond to which walk-in: -A, -B, -C, -D, etc.

Note that panels and lock locations are always described from the interior. From this vantage, the male (tongue) edges of wall panels are usually on the right side of the panel.

**IMPORTANT!** Always consult with your General Contractor before installation of your walk-in box in a recently poured concrete pad or tiled floor to ensure enough curing time has been allowed.

Concrete, grout, and other construction materials may outgas chemicals for weeks (or even months) that can cause staining/corrosion of walk-in cooler metal surfaces. Muriatic acid liquid and fumes, which is often used by concrete contractors, will also cause staining/corrosion. We recommend that our customers and their General Contractors fully understand the cure time of the concrete, tile grout, and any other materials in proximity to the walk-in and provide adequate ventilation to move these gases out and away from the walk-in cooler. Inadequate ventilation or ventilation for too short of a time may result in staining/corrosion of walk-in cooler metal. This staining/corrosion is not covered by warranty. If in doubt, contact your concrete supplier, tile contractor, general contractor, etc. for the number of days for the concrete, grout, and other construction materials to have fully outgassed and install your walk-in cooler after this date.

**2.2 FLOOR PANELS**

A moisture barrier of 4-mil polyethylene (supplied by others) must be laid between the floor panels and the existing floor and overlapped at least six inches at joints.

Start with a floor end section in the proper location according to the layout drawing. Floor panels must be level on both length and width. Next, place the appropriate adjoining center or end section into position. Ensure that all edges are flush and level, then lock the panels together and again check for levelness. As you proceed with assembly of the floors, check that the chalk line is being followed. Complete the assembly of the remaining floor panels in the same manner.

**Leveling walk-ins with floors**

If the surface is not level, the floor must be leveled using a leveling bed (supplied by others) or installing shims (supplied by others) under the corners and cross panel joints, as needed, to ensure proper support and levelness of panels. Shims under floor panels must be 23" on center or less, to provide adequate support to the walk-in. Shimming only the outer edges may result in damage to the walk-in.

## 2.3 FLOORLESS WALK-INS

### Leveling walk-ins without floors

Floorless walk-ins will be attached either directly to the existing floor or to screeds. If surface is not level, place shims under the panel and within the screed.

### 2.3.1 Coolers

Floorless coolers are provided with a vinyl or metal floor screed which should be placed along the chalk lines described in Section 2.1 (fig. 3).

For **metal screed installations**, install the steel track driving the anchoring pins into the floor at 24" O.C. Always check with local inspectors, before and during installation, as requirements in depth of penetration and spacing of the anchoring pins can vary depending on local regulations. After track is installed and panels are erected, install the interior and exterior metal cove bases by screwing them to the face of the wall panels and applying a bead of sealant atop the cove both inside and outside the cooler (see Fig. 5).

For **vinyl screed installations**, a bead of caulk should be applied on each outside bottom edge, between the floor and the screed to compensate for any minor irregularities in the building floor. Check squareness of the corners, check dimensions and then secure the screed into position with concrete nails or anchors (supplied by others) as shown in Fig. 5

The factory provides enough tubes of caulk for a typical installation (1 tube/15ft); however, more may be needed if the building floor or slab is particularly rough.

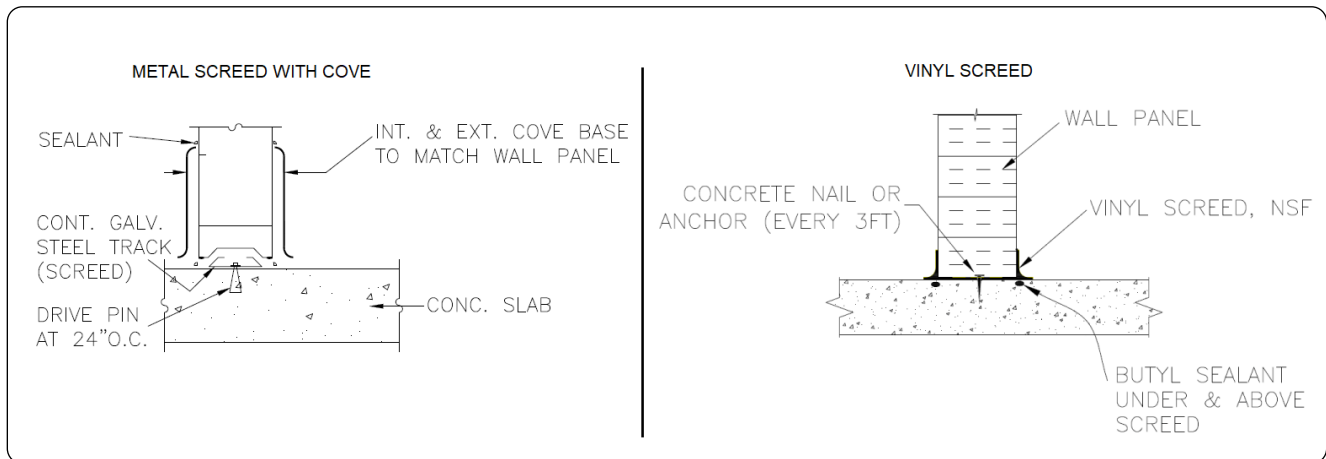

FIG 5. FLOOR SCREED

### 2.3.2 Freezers

"Floorless" freezers are provided with the understanding that the customer will be providing an insulated floor. This is commonly achieved with a poured concrete slab over insulation incorporating a vertical thermal barrier under the walk-in walls between the insulation and the slab's surface as shown in Fig. 6.

In this application, Arctic normally provides interior and exterior floor angle to attach the walls to the floor. The angle, is attached to the floor with anchor bolts or concrete nails (hardware provided by others) and to the walk-in walls with sheet metal screws. Care must be taken not to chip the edges of the slab.

Please read important note on page 5 about concrete floors and curing time.

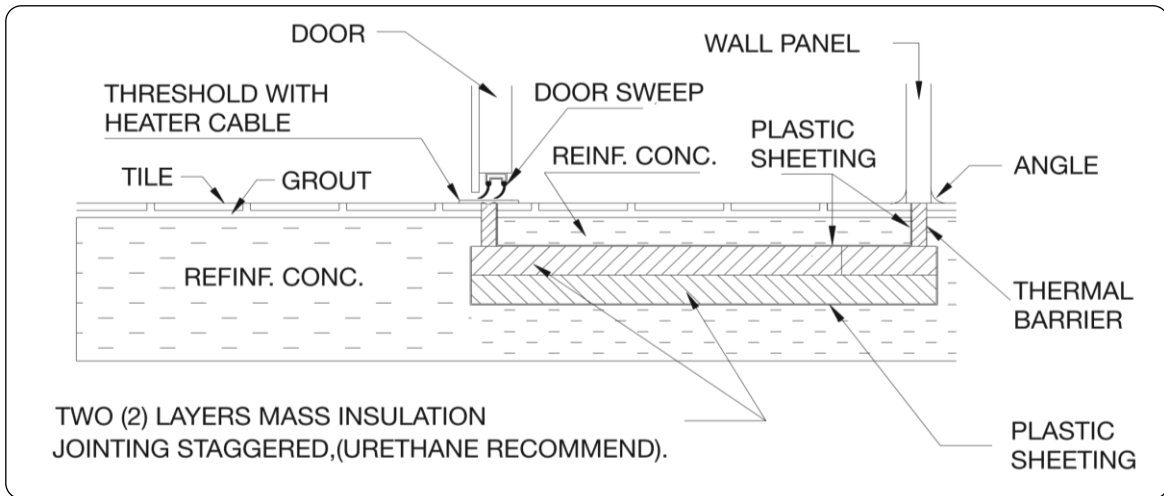

**FIG 6. INSULATED SLAB**

### 2.3.3 Combinations

For combination walk-ins with a floorless cooler section and freezer with a floor, a half-screed piece is provided for the edge of the freezer within the cooler section. This piece must be attached beneath the freezer floor to match the rest of the screed on the interior of the cooler section as shown in Fig. 7.

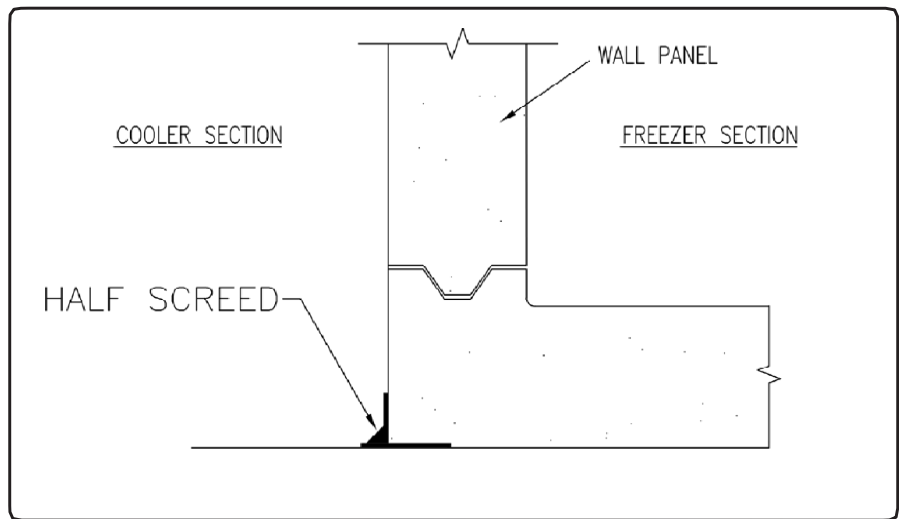

**FIG 7. COMBINATION: COOLER FLOORLESS / FREEZER WITH FLOOR**

## 2.3 WALL PANELS

Review the layout drawing and select a corner to start the assembly of the walls. We suggest that you start with the most inaccessible corner or one adjacent to your building wall.

Place the corner panel even with the outside of the floor or the chalk line if floorless. Partially lock the corner panel to the floor. Now select a wall panel to install on the right side of the corner. Lock this panel firmly to the corner in such a way that their tops are level. Partially lock the wall panel to the floor panel.

Continue in the same fashion, making your way around the cooler on both directions and checking for levelness across the tops of the wall panels. Install the door panel (See 2.4 Door Panels) and leave a front corner panel as the last wall panel to be installed. When possible, choose a corner panel that is easy to access and not next to an adjacent building wall.



Once all wall and door panels are installed, checked for levelness and door plumbed and squared as described in 2.4 (Door Panels), you can proceed to permanently lock all the wall panels to the floor.

## 2.4 DOOR PANELS

When installing doors, first remove the door from its frame section. To remove the door, open it past 90 degrees and carefully lift it off the nylon hinge pins. Note the position of the cam faces on the pins before re-installing the door. They must be in proper position so that door will self-close. **Proper door operation requires that the door frame members be perfectly plumb and square. Replace the door in its frame before securing the jambs to the floor and check to see that the door closes, seals, and locks properly.**

Cooler door frames without heater cables are shipped with a metal or wood spreader plate joining the two frame legs at the bottom. This should be removed before fastening the frame to the floor. Secure door frame legs to the interior floor, using the door frame brackets and screws provided.

**IMPORTANT NOTE:** Door and frames have been checked for proper fit and operation at the factory. An unlevel floor may cause doors to not hang or close properly. This can occur initially at the time of installation or at later date after traffic and the weight of stored product have caused the floor panels to settle. It may be necessary to shim under walk-in floor or door frames at one side or other to adjust a misaligned frame. Loosening and relocking frame cam locks may also permit some adjustment. Make sure frame legs are parallel to each other and to adjacent wall panel. The door may not seal properly if the frame is twisted or out of plumb. See Fig. 8 on next page.

### Door Panels on Floorless Walk-ins

Door frames are attached to the floor in the same manner as walk-ins with floor except that concrete anchors must be used. Cooler doors are provided with threshold plates only in the special cases where a heater is requested; therefore, the metal or wood “shipping brace” must be removed from the bottom the door frame legs before the legs are attached to the floor. **NOTE:** Shipping brace not on shown on Fig. 8 on next page.

### Door Panels General Electrical Information

All electrical installations must be done by a qualified electrician. All electrical connections should be made to comply with national and local codes.

Door frames are prewired at the factory. The light fixture above the door serves as a junction box for electrical hook up of the light and light switch (See section 2.9.2).

In Freezer door panels, a door heater cable is installed and pre-wired at the factory to prevent frost around the door frame. A *Thermo Disc* is mounted inside the light fixture junction box and wired at the factory with the heater cable. The *Thermo Disc* will prevent the heater cable from energizing if the temperature of the box is above 40°F; once the temperature is below 40°F it will energize the heater cable. In freezer sections, a heated pressure relief port may be provided and must be connected. (See section 2.9.2 for details).

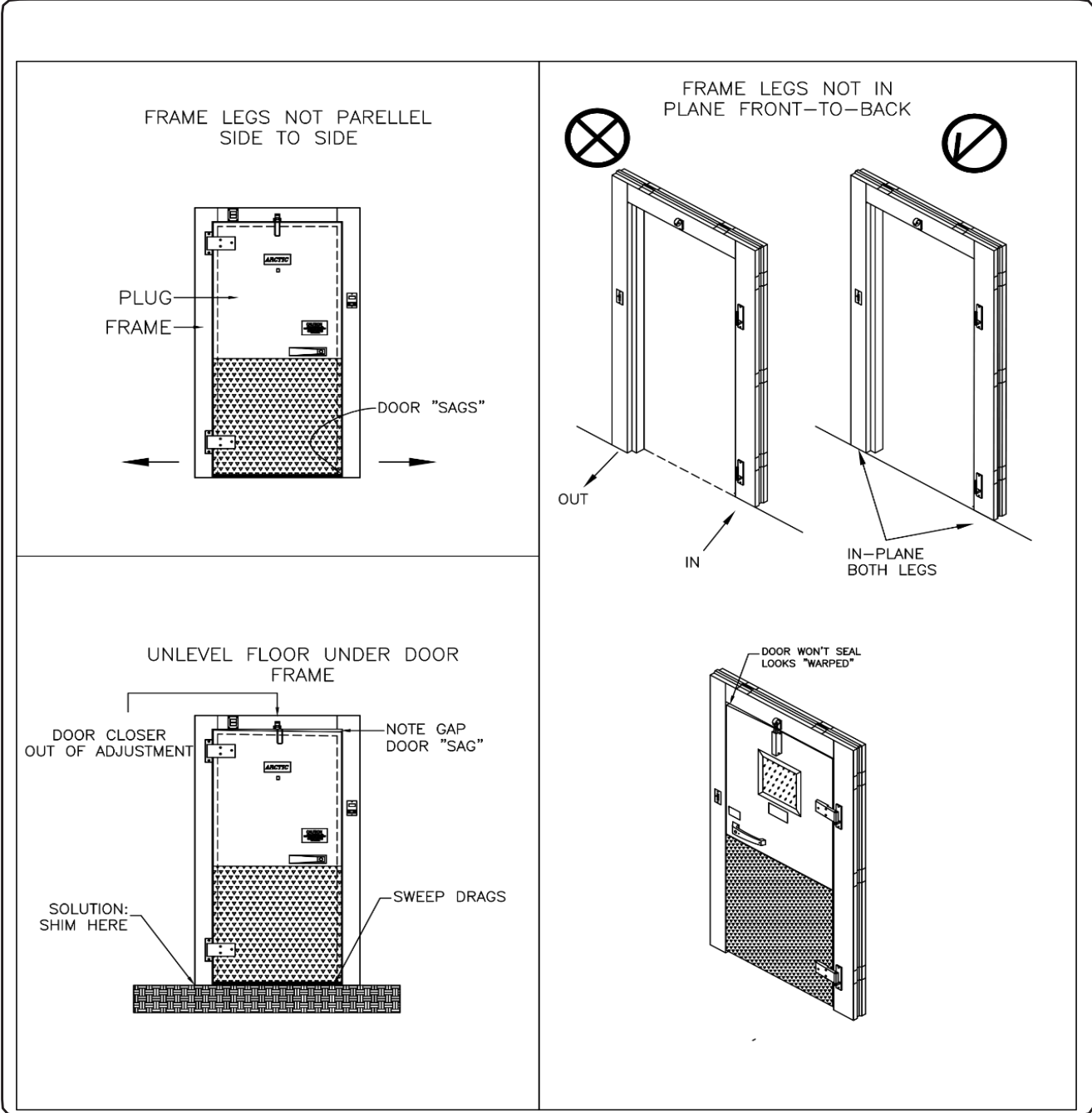

**FIG 8. INSTALLATION DOOR PROBLEMS**

## 2.5 CEILING PANELS

Refer to the layout drawing and select the end ceiling panel adjacent to your building wall. Place this panel into position and carefully align it with the corner and side wall. Lock it firmly to the corners and along the back wall, but not to the side walls. Select the next ceiling panel, as shown on the layout drawing, and carefully align it with the edges of the end ceiling and the walls.

After you are satisfied with the alignment, firmly lock the ceilings together along the center seam, but lock only loosely to the walls.

Continue placing ceiling panels in the same manner, until the opposite end section is installed. Now carefully check the alignment of the ceiling with the corner and perimeter walls, and once you are satisfied, complete the firm locking to the wall panels.

For ceiling panels with clear span over 14' in both directions, ceiling support may be supplied as shown in Fig. 9.

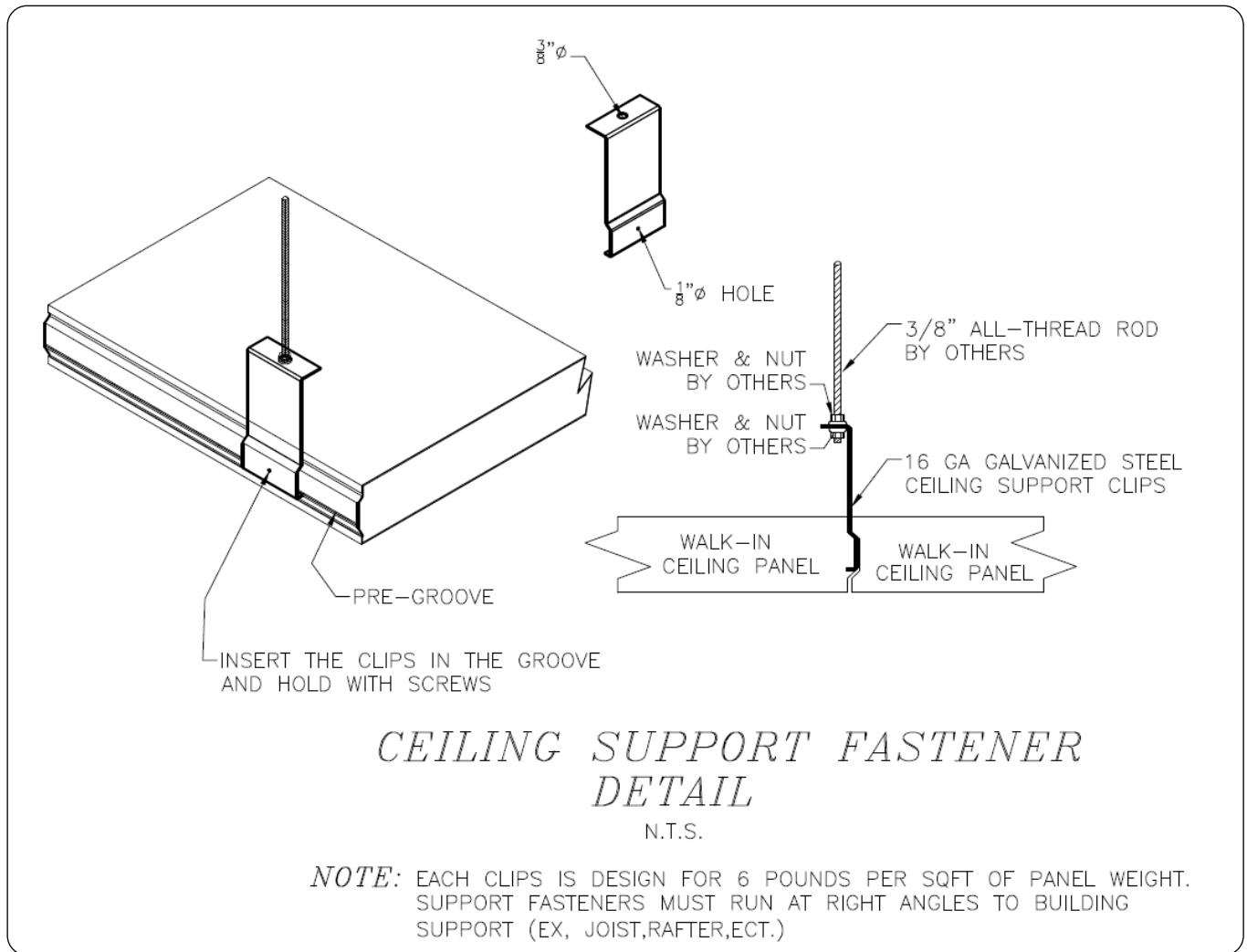

**FIG 9. CEILING SUPPORT FASTENERS**

## 2.7 OUTDOOR INSTALLATION

### 2.7.1 Roof Covers

Walk-Ins installed outdoors must be protected with a membrane roof cover. If the walk-in has a self-contained refrigeration system please see section 2.9.3 (Page 16) before proceeding to install the roof membrane.

#### The membrane roof consists of:

1. Membrane roof cover
2. Termination Bars (Term bars)
3. 1" Phillips head sheet metal screws
4. 1" Hex head screws with neoprene washers
5. 2" Flat head plates
6. Caulking

**The following procedure must be followed to insure proper weather protection.** See Fig. 10.

1. Unpack your roll, being careful not to cut the membrane.
2. Unroll the membrane over the roof area, being sure the tabs are on the underside. Roof area to be free of all debris.
3. Maneuver and/or shift the membrane so it fits squarely over the roof area, allowing equal amounts of membrane to overhang at least 6" on the edges of the roof. If windy conditions are present, use concrete blocks, tires, lumber, etc., around the perimeter to keep the wind from lifting the membrane.
4. Once the membrane is centered on the roof, either fold or roll the membrane back towards the center of the roof so the underside tabs are exposed. The roll or fold must be parallel to the factory seam and tab.
5. When you reach the tab going in the opposite direction, stop rolling or folding.
6. Now begin to roll or fold the roll back until a tab is exposed.
7. The tab should be flat on the roof deck.
8. Install the 2" Flat head plates along the fastening tab using the 1" Philips screws, keeping them spaced 12" O.C.
9. Continue to roll the membrane until the next tab is exposed and in place, ready for fastening.
10. Pull this tab tightly to reduce any wrinkle that may occur. Once pulled tight, hold in position until secured with a couple of fasteners.
11. In a similar manner install the fasteners along the tab 12" O.C.
12. Continue steps 10 & 11 until you reach the last tab.
13. For large roof surfaces repeat the same process with another roll, only starting at the other end of the roof, following the same procedures and staggering the seams at about 27" O.C. See Fig. 10.
14. You should have at least six inches of membrane overhanging the edge of the roof. Holding this overhang tight, down over the edge, install the termination bar at least 5" below the horizontal roof. If the term bar has a caulking lip, have the lip on the upside.
15. Fasten the term bar 8-12" O.C, using fasteners with neoprene washers.
16. After all term bars are attached, trim excess membrane that is exposed under the term bar with a sharp knife, using the bottom edge of the bar as a cutting guide.
17. Now caulk the top edge of the term bar with the caulking provided. Your roof should now be completed.

#### NOTES:

1. Keep sharp objects off the roof, such as nails, screws, etc. Someone stepping on them could puncture the membrane.
2. Caution! The membrane is very slippery when wet.
3. Any puncture or holes that may occur during installation can be temporarily repaired with duct tape or caulking. A final repair must be done using a heat gun.
4. Do not drop hot cigarettes or objects on the membrane.

**Membrane roof roll-out and fastener placement for large roof surfaces:**

1. Paneled roll.
- NOTE: roll remains behind previously fastened tab during roll-out
2. Factory tab
3. Approved fastener w/barbed stress plate
4. Approved fastener w/barbed stress plate approximately 27" o/c
5. Factory welds, staggered equidistant between factory welds of adjacent roles 27" o/c
6. Side lap roll to roll minimum 4 1/2"

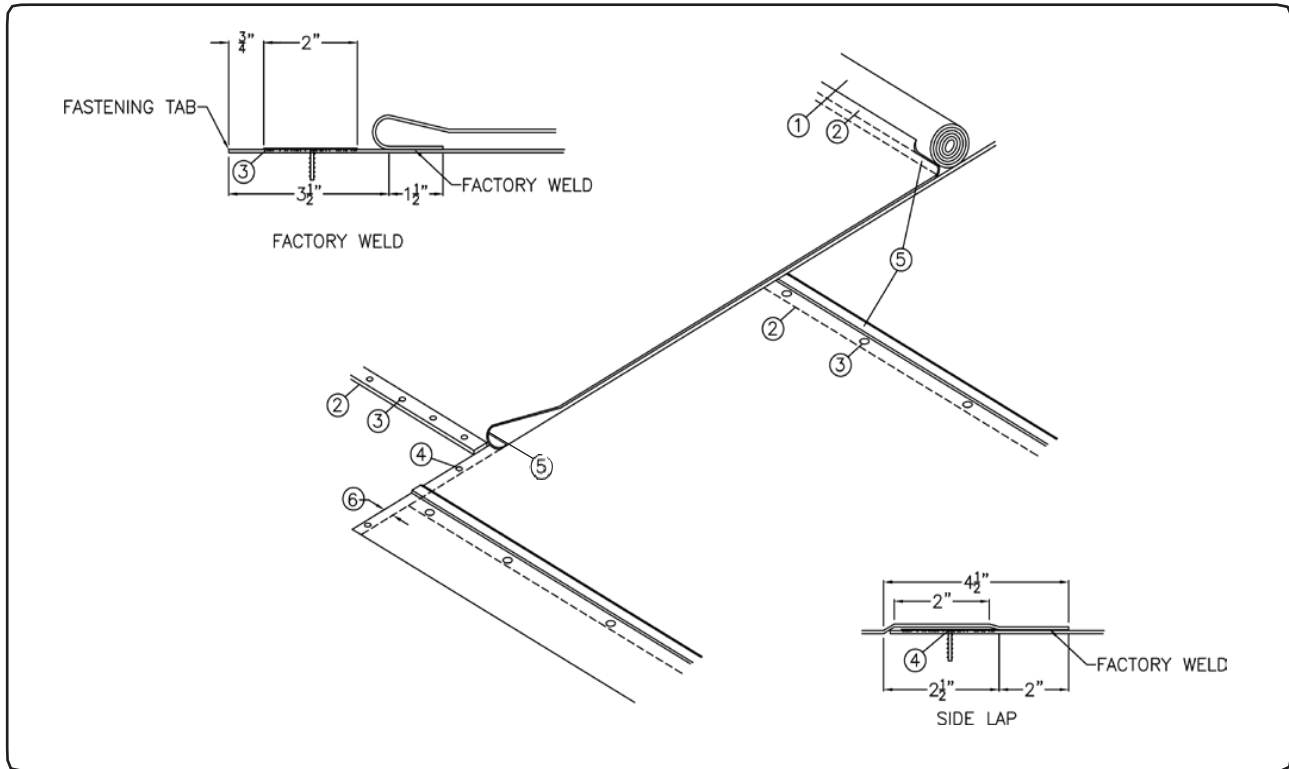

**FIG 10. MEMBRANE ROOF ROLL-OUT AND FASTENER PLACEMENT DRAWING**

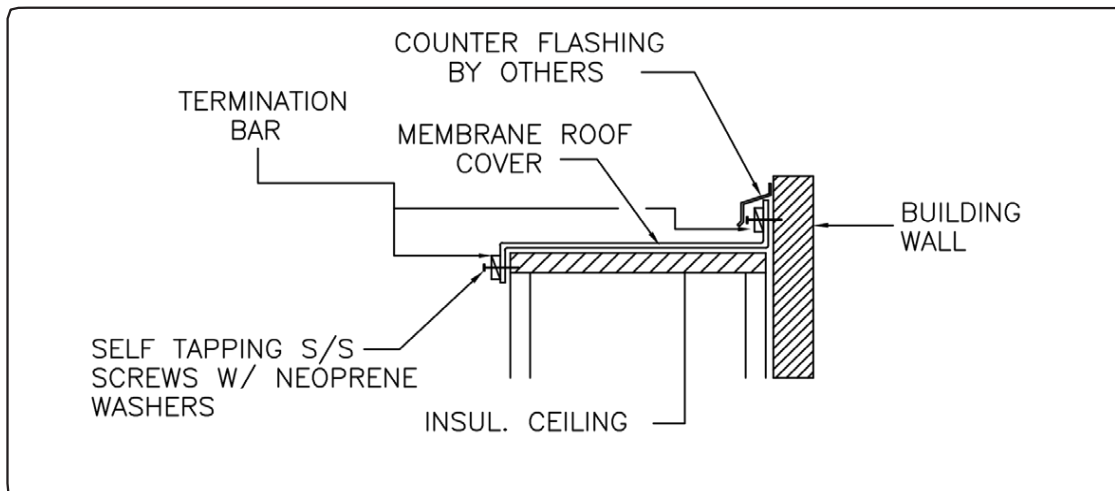

**FIG 11. TYPICAL MEMBRANE COVER INSTALLATION WITH ADJACENT WALL**

## 2.7.2 Door caps

For free-standing walk-ins where the door is exposed, Arctic offers an optional door cap to prevent rain water from running down into the door gasket. The cap should be attached with sheet metal screws (supplied by others) to the frame above the door, caulk the joint between cap and wall to prevent leaks.

## 2.7.3 Box-to-Slab Attachment

An outdoor walk-in is usually placed on a raised concrete slab. Local codes may require that the walk-in be attached to the slab using perimeter angle (supplied by others). This angle is attached to the edges of the walk-in floor or walls with sheet metal screws and to the slab with concrete nails or anchor bolts supplied by others (See Fig. 12).

Be sure to allow enough distance between the edge of the walk-in walls/floor and the end of the slab to prevent the edges from cracking away due to pressure of the fasteners.

Apply sufficient caulking between the angle and both the slab and walk-in to deter water infiltration.

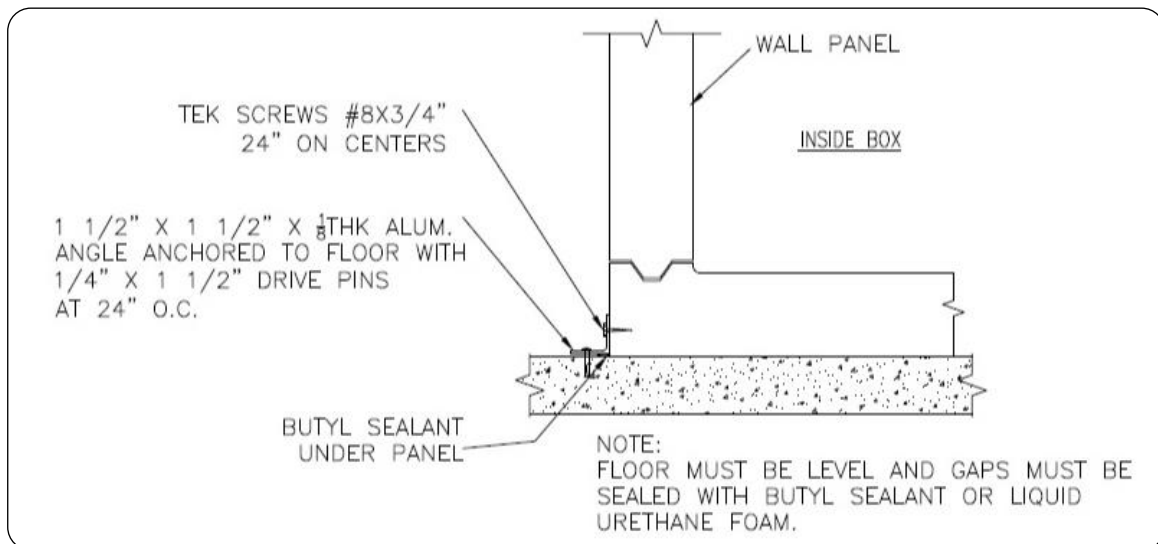

FIG 12. BOX TO SLAB ATTACHMENT

## 2.7.4 Snow / Ice Load

To avoid ceiling failure/collapse due to snow/ice (not covered by the panel warranty), snow accumulation of more than 3" must be carefully removed in a manner which does not cause damage (tears, etc.) to the membrane roof cover.

## 2.8 DIAMOND TREAD PLATE INSTALLATION

Beer coolers and other walk-ins subject to heavy use, frequently require an overlay of aluminum Diamond Tread Plate (DTP) on the walls and/or floors. DTP should be applied prior to start-up of refrigeration

### 2.8.1 Wall Panels

1. Remove all dust, dirt, grease, etc. from wall panels and back of DTP using mild soap, and allow panels to dry.
2. Lay out DTP in appropriate order. With complicate lay-outs DTP will be marked on back with a code number that corresponds to a code number shown on the drawing that accompanies the walk-in.
3. Apply adhesive (supplied) to rear (smooth side) of DTP in a serpentine patten. See Fig.13. **Do not apply adhesive around perimeter of DTP as this will prevent air from reaching all of the adhesive which**

**will slow the curing process.** A thin line of adhesive is recommended to make contact with the wall panel. One tube of adhesive to every 4' x 10' sheet of DTP is more than sufficient. See Fig. 13.

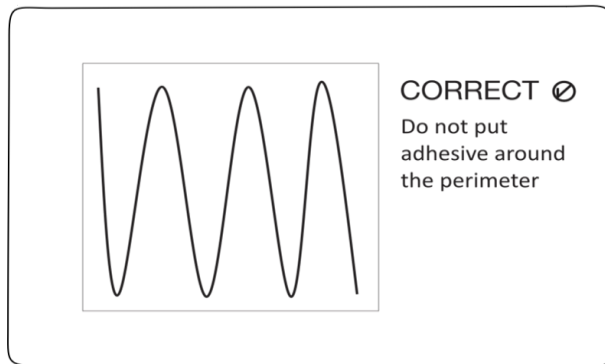

**FIG 13. CORRECT ADHESIVE APPLICATION FOR DIAMOND TREAD**

4. Use tape (supplied by others) to hold the DTP in place (while adhesive cures) and anchor the DTP using #8x2" self-drilling screws with flat washers around the perimeter of DTP approximately every two feet.
5. Allow 24 hours at ambient temperature for adhesive to cure. Leave doors open to allow for proper ventilation of walk-in.
6. After 24 Hours, apply silicon (supplied) on exposed edges and corners of DTP to fill any gaps.

### 2.8.2 Floor Panels

1. Installation is essentially the same as for wall panels.
2. All DTP floor seams should be bedded in a 4" wide band of USDA silicone caulking (provided) to inhibit moisture from seeping through the seams of the DTP. Allow sufficient time for caulking to cure prior to start-up of refrigeration.
3. TEK screws are provided to fasten DTP to floor.

## 2.9 COMPLETING THE INSTALLATION

Several tasks remain to complete the installation of your Arctic Walk-In. Some of these are the installer's responsibility while others must be performed by qualified electrical and/or refrigeration contractors.

### 2.9.1 By Installer

1. Install snap-in plastic caps to seal cam-lock access holes.
2. Fasten down thresholds, if provided (see Fig. 14). Make sure that any door heater wires are not frayed or pinched.

**NOTE:** Thresholds with anti-condensate heater wires under them (all freezers & some coolers) must be made to be removable in order to change the heater wire should it fail. Never allow tile or concrete to cover either the threshold or its fasteners.

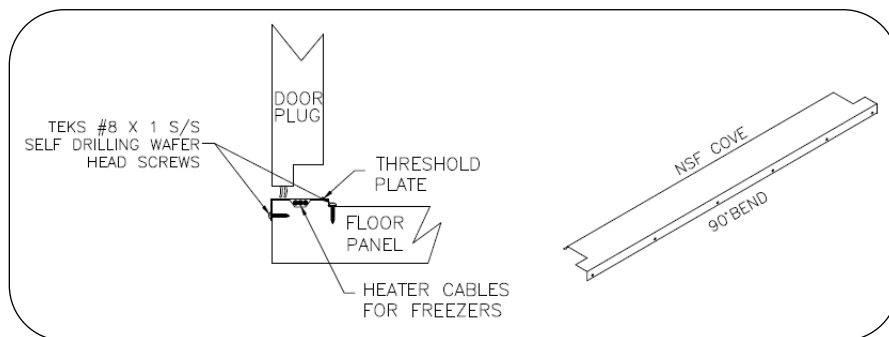

**FIG 14. DOOR THRESHOLD DETAIL**

**Important Note to General Contractor and Sub-contractor:** For walk-ins with tile or concrete wearing floors installed after the walk-in, the metal wall facings may be susceptible to staining due to excessive moisture created by hydration of concrete-type materials. It is essential that the area be properly ventilated, especially when using muriatic acid due to its effects on aluminum and stainless steel.

Additionally, metal surfaces must be protected from lime and other chemicals found in cement products. Protection must be applied between concrete and the metal surfaces (for example, liquid tar brushed or sprayed above the concrete contact line, heavy epoxy paint, double-layered 8-mil H.D. polyethylene, or 30 lb. asphalt-impregnated roofing paper).

### 2.9.2 By Electrical Contractor

All electrical connections should be made to comply with national and local codes. Run electrical power supply (115V-3-Wire), 15amp to the light fixture which also serves as a junction box. The penetration can be made through a ceiling or wall panel, and must be properly sealed both inside the conduit and outside. *Please refer to the electrical schematic provided with your walk-in for additional information.*

**NOTE:** To prevent condensation from forming inside, electrical conduit must be sealed internally where it enters cold space and externally (see Fig. 15). Wall or ceiling penetrations must not interfere with panel seams or locking devices (See Fig. 15).

In freezer sections, a heated pressure relief port may be provided and must be connected. A *Thermo Disc* is mounted inside the light fixture junction box and wired at the factory with the heater cable. **The *Thermo Disc* will prevent the heater cable from energizing if the temperature of the box is above 40°F; once the temperature is below 40°F it will energize the heater cable** (See Fig. 15A).

Run power to the mechanical refrigeration equipment as required by the equipment manufacturer.

Be sure to use an electrical seal-off on the exterior of the walk-in wherever lines penetrate the exterior metal surface.

**Do not penetrate the roof cover of outdoor walk-ins.**

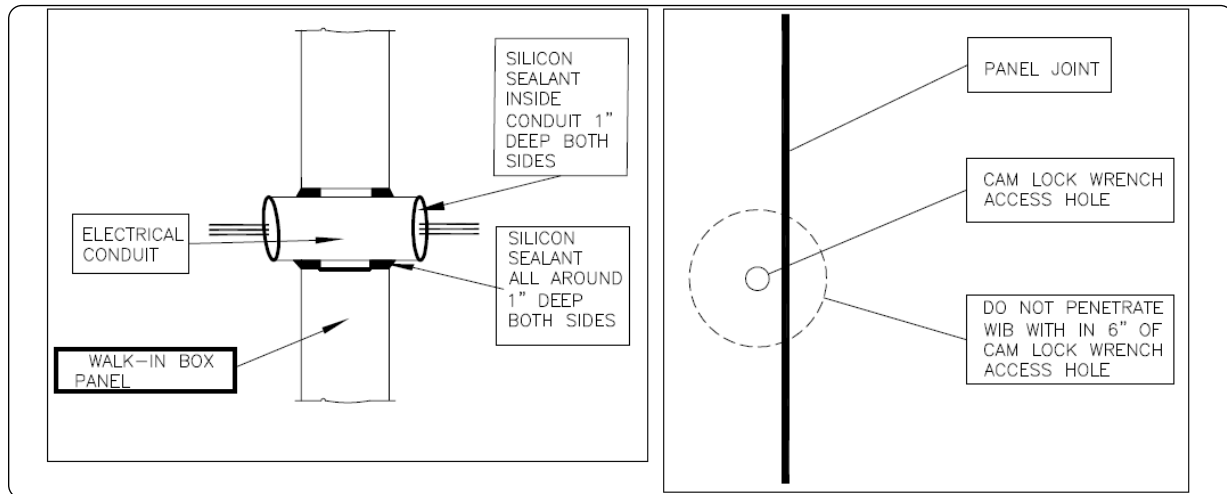

**FIG 15. SEALING OF WALK-IN ELECTRICAL PENETRATIONS**

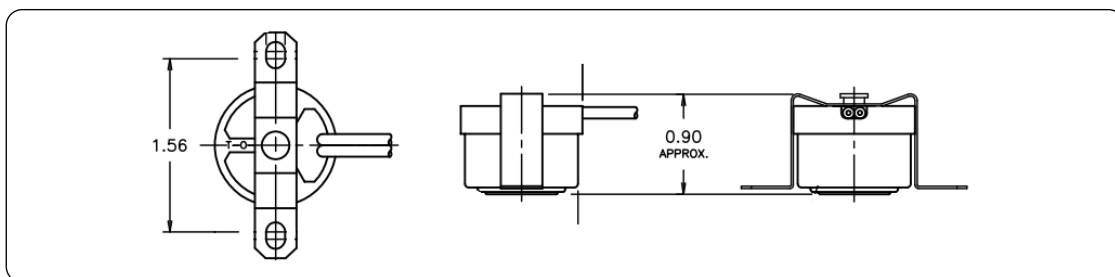

**FIG 15A. THERMO DISC DETAIL**



### 2.9.3 By Refrigeration Contractor

Install mechanical refrigeration equipment in compliance with national and local codes.

#### General installation recommendations for all refrigeration units

Refrigeration installation and start-up should be performed by a qualified refrigeration contractor as variation in field conditions such as altitude, walk-in temperature, product load, ambient temperature and humidity, frequently require adjustments to thermostat, expansion valves (superheat), pressure control or defrost settings. Operations in extreme low ambient conditions may require variations in refrigerant charge. Extreme high ambient conditions may require additional accessories (not included)

Drill clean holes through the walk-in wall for condensate drain and refrigerant lines. **DO NOT PUNCH.** All penetrations must be clear of panel seams and locking devices and be sealed completely inside and outside. Remote low temperature systems include a 6' drain-line heater cable which should be wrapped around the drain line to prevent freezing. If a longer drain heater cable is required it must be provided by others. **The use of PVC for freezer drain lines is not recommended;** soft copper should be used.

Low temp systems also include a defrost timer which must be set by the installer to initiate the time and control the duration of defrost cycles. The frequency of cycles is determined by the usage of the walk-in (frequency of door openings, ambient temperature and humidity as well as product load) and their duration by the amount of frost to be removed. Keep both to the minimum necessary to maintain temperature and to keep evaporator coils free of built-up frost.

Evaporator fans should run continuously on medium temperature systems and intermittently (off during defrost) on low temperature systems. Low temp fans do not come on until the evaporator temperature gets down to about 25°F (-4°C). See evaporator manufacturer's instruction for specific installation and operation details.

#### General installation recommendations for self-contained units

Self-contained refrigeration units are fully inspected and tested at the factory prior to shipment.

**WE STRONGLY** recommend that **start-up** of self-contained units be performed by a qualified refrigeration contractor as variation in field conditions such as altitude, walk-in temperature, product load, ambient temperature and humidity, frequently require adjustments to thermostat, pressure control or defrost settings. Operations in extreme low ambient conditions may require variation of refrigerant charge. Extreme high ambient conditions may require additional accessories (not included).

Side-mount units must be attached to the frame of their wall openings using the same carriage bolts which secure them to their shipping crates. Top-mount units are placed in their openings with no need of attachment.

In some cases, it may be convenient to place the ceiling-panel top-mount unit in its opening before the ceiling panel is lifted into place, as in many of this situations, four installers can lift the panel and unit together. **Heavier units will require the use of mechanical lifting equipment.**

On self-contained units be sure to uncoil the drain-line heater (if applicable) before applying power to the unit or the heater will be damaged.

#### **Installation of outdoor self-contained units (see Fig.16 next page)**

1. Pressure Treated Wood Base (supplied by Arctic) shall be fastened securely to the box ceiling by bolting through with carriage bolts (supplied by others).
2. The membrane roof cover shall be fastened to the box covering the curb. After the roof cover is in place, open a hole on the roof cover where the evaporator is going to be (25' x 38' size) over lapping the membrane by an inch, secure it to the curb.
3. Secure the unit to the roof curb. Seal screw heads as necessary to prevent moisture from entering beneath membrane.

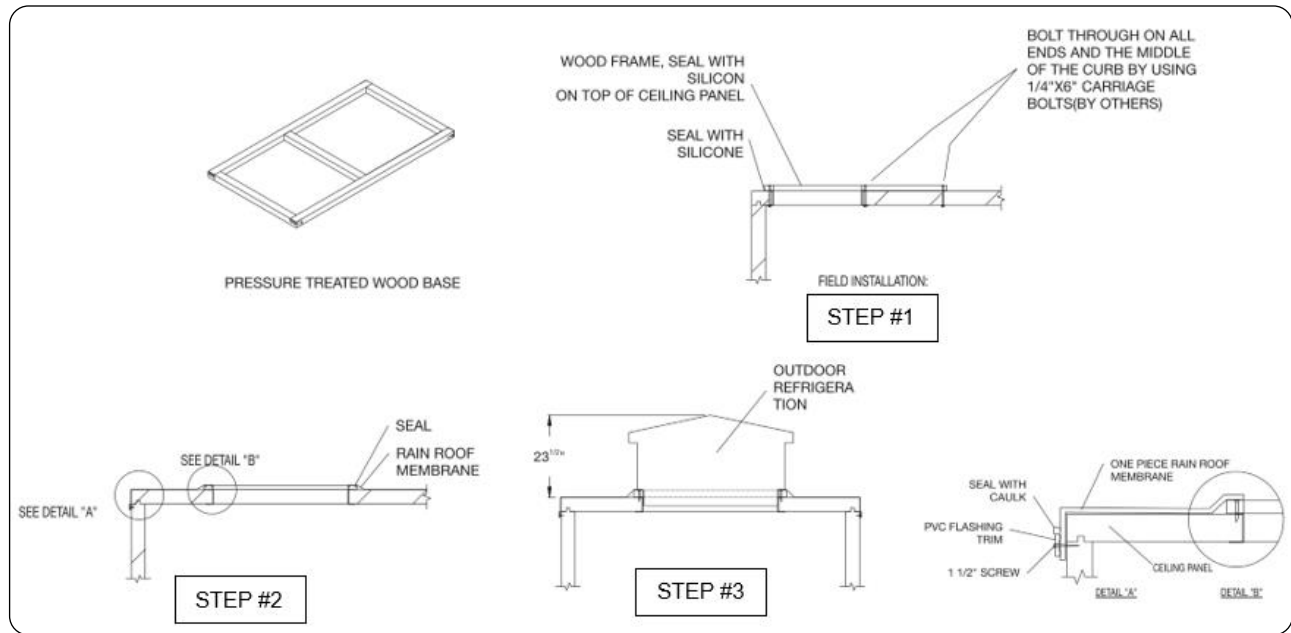

**FIG 16. INSTALLATION OF OUTDOOR SELF-CONTAINED UNITS**

## 2.9.4 Compressor and walk-in Warranty Card

**IMPORTANT! REGISTRATION REQUIRED!**



REGISTER YOUR WALK-IN ONLINE at <https://www.arcticwalkins.com/>

THE WARRANTY WILL BECOME EFFECTIVE ONLY UPON RECEIPT BY ARCTIC OF THE "FULLY-COMPLETED" WARRANTY REGISTRATION ONLINE FORM.

## 2.9.5 Thermometer Adjustment

### Dial Thermometer (Optional)

The dial thermometer on the door frame may need to be set to reflect accurately interior temperature of the walk-in.

To calibrate, pop off the plastic lens using a thin-blade screwdriver in the slots provided. With the same screwdriver, in the slot of the thermometer's pointer hub, hold the tail of the pointer with your finger as you gently turn the screwdriver. Clockwise to decrease the temperature reading and counter-clockwise to increase your temperature reading. Re-check the temperature and press the lens back into place.

### Digital Thermometer (Optional)

Digital thermometer with light switch is pre-wired and mounted on the door frame. Please consult factory for any calibration or alarm display issues.

## SECTION 3: MAINTENANCE

Your walk-in was designed and manufactured to offer you many years of trouble-free service. Appropriate maintenance and care will protect your investment and prolong the useful life of your walk-in.

### 3.1 CLEANING

To maintain the appearance of the walls, clean periodically with warm water and a mild soap solution. Dry thoroughly to prevent ice buildup. Do not use caustic or abrasive cleaners. Use only a damp mop to clean floor panels. **DO NOT HOSE DOWN OR POUR WATER ON FLOOR PANELS.** Panel seams are designed to hold temperature not water.

Under no circumstances should hydrochloric (muriatic) acid be used to clean any part of the walk-in. Damage may result from using this or any other harsh chemicals.

Clean spills immediately! Use warm water, mild soap, and dry thoroughly. **PERSONAL INJURY MAY RESULT FROM SLIPPERY FLOORS.**

Clean door gaskets regularly- use baking soda and warm water mixture and wipe dry with a soft cloth.

Be certain that there is sufficient air circulation around the compressor. To prevent overheating, periodically remove any grease and dust buildup from the condenser coil and fins.

### 3.2 DOOR HARWARE

Lubricate hinge pins and sockets with petroleum jelly at least once a year.

Periodically check hardware to ensure that fasteners are firmly anchored.

### 3.3 CEILING

Standard ceiling panels are not designed to support any weight but their own. If it is necessary to put a condensing unit on top of the walk-in, it should not exceed 300 lbs. gross weight and should only be placed as close as possible to a corner or wall panel.

**DO NOT STORE GOODS ATOP THE WALK-IN NOR PERMIT PEOPLE TO WALK ON THE CEILING PANELS.**

Heavy light fixtures and conduit which are attached only to the interior surface skins of ceiling panels may cause separation of metal from foam. Heavy fixtures should be through-bolted using nylon all-thread rods to minimize thermal (cold) transfer and consequent moisture condensation.

**Snow / Ice Load:** To avoid ceiling failure/collapse due to snow/ice (not covered by the panel warranty), snow accumulation of more than 3" must be carefully removed in a manner which does not cause damage (tears, etc.) to the membrane roof cover.

## SECTION 4: SERVICE

### 4.1 DOOR CLOSER

The door closer has been adjusted at the factory so that the rubber roller just touches and slightly turns as it passes the tip of the hook when the door is closing. See Fig. 17. When properly installed, the door is self-closing and should not be slammed. Slamming the door may cause the door closer to come out of alignment.

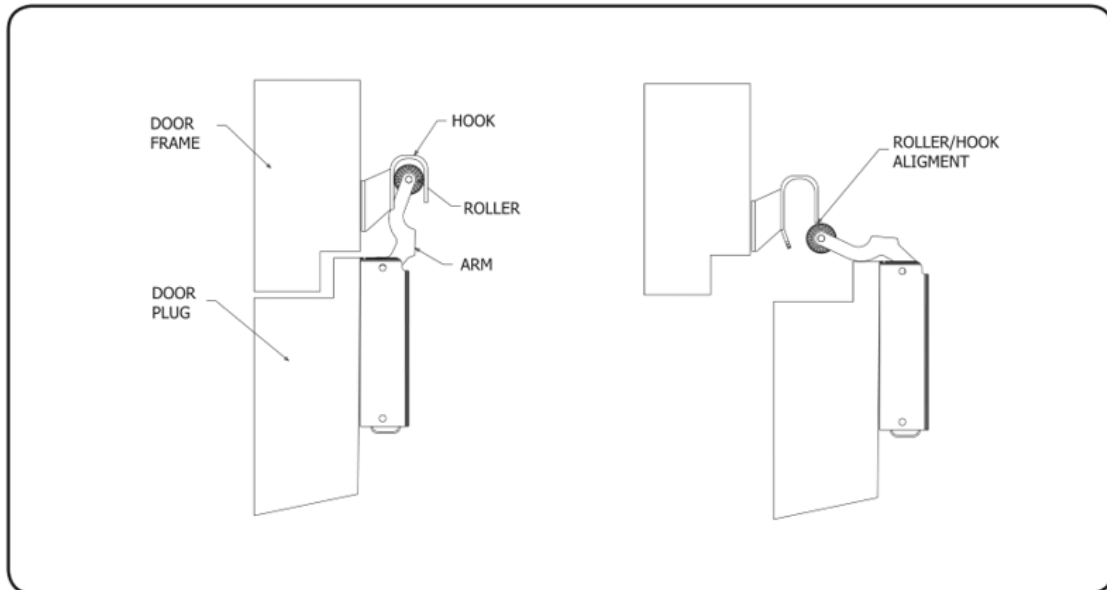

FIG 17. DOOR CLOSER

Readjustment of the door closer can be accomplished by the addition of washers under the top fastening screws, in order to lower the hook. Washers installed under the lower screws will raise the hook. See Fig. 18.

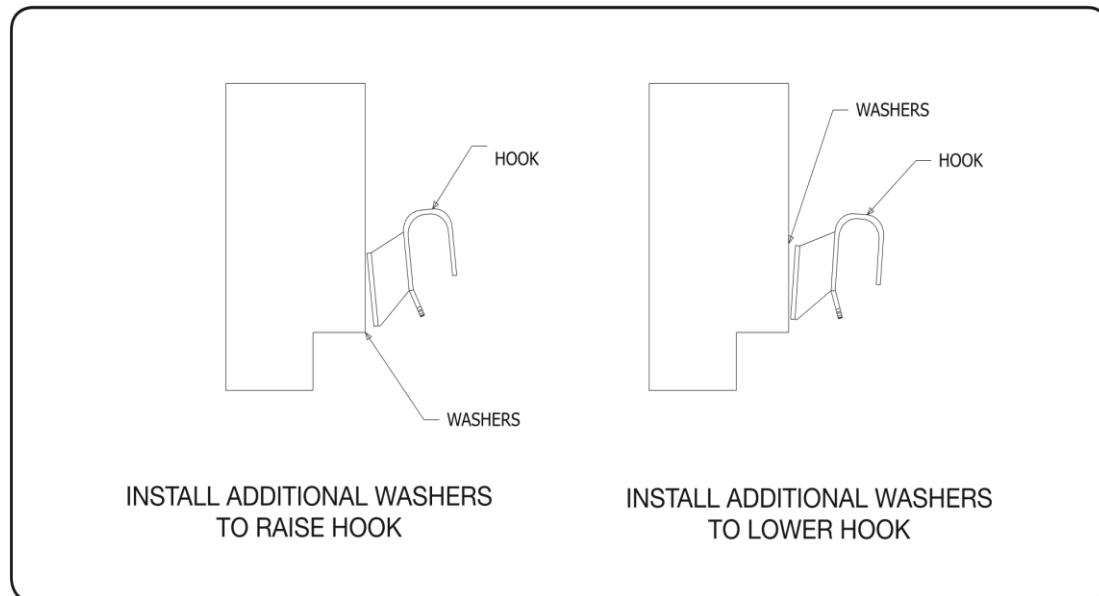
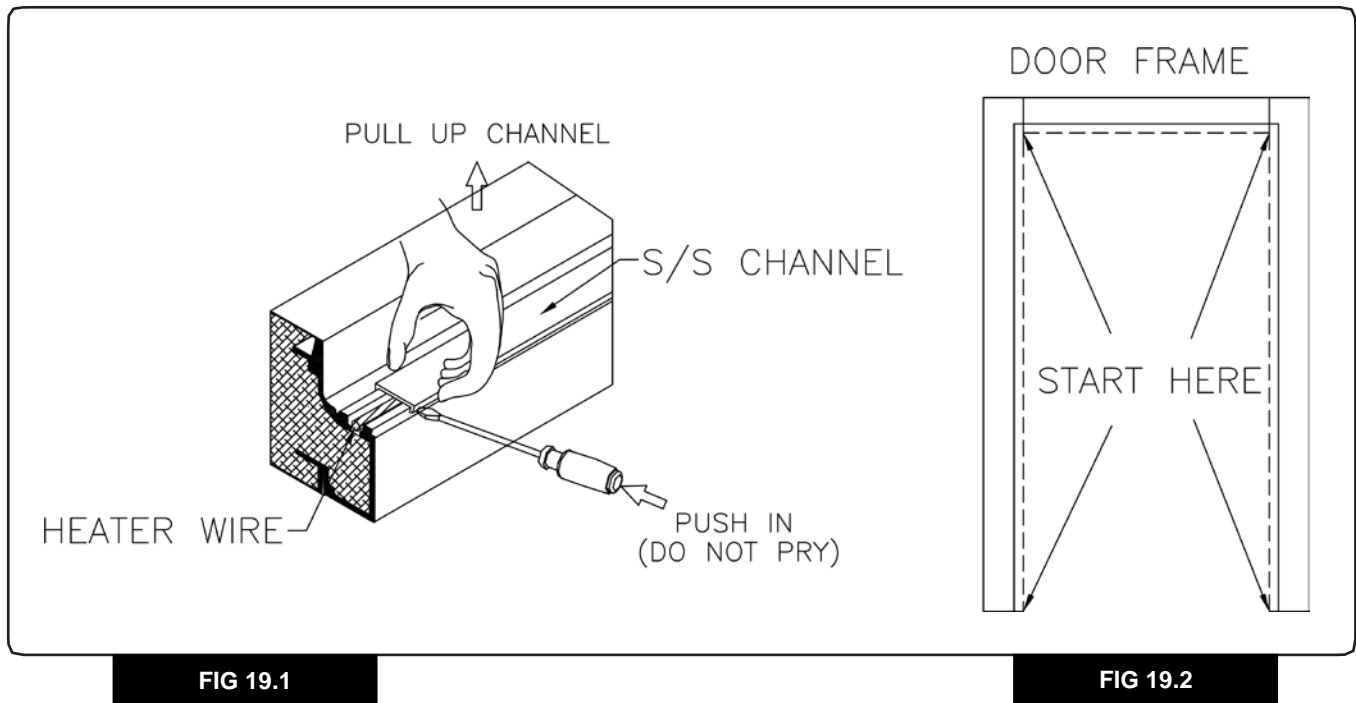

FIG 18. RE-ADJUSTMENT OF DOOR CLOSER

## 4.2 HEATER DOOR REPLACEMENT

**NOTE:** A *Thermo Disc* in the wire circuit will keep the heater wire from turning on until the inside temperature gets down to about 40 degrees. **Ensure this *Thermo Disc* is working accordingly before replacing the heater cable!**

1. The door heater is connected to the same power supply as the light fixture. **TURN POWER OFF AT THE SOURCE!**
2. Remove threshold
3. Using a thin-blade screwdriver apply pressure (not leverage) to the door frame extrusion as shown in Fig. 19.1. Pull the Stainless Steel (S/S) channel Snap-On cover with your hand as shown. Always start at one end as indicated in Fig. 19.2 and continue the operation described above until the entire cover is removed.
4. Remove globe from the vapor proof light fixture
5. Remove receptacle plate on vapor proof light junction box and disconnect heater wire leads.
6. Remove defective heater wire.
7. Install replacement heater wire. Tack with permagum sparingly in order to hold wire in place in its channel.
8. Reinforce with aluminum foil tape (two wraps) at four corners.
9. "Snake" heater wire at threshold taking extra care not to overlap wire, or allow wire to touch itself. Tack down with permagum and foil tape.
10. Reconnect heater wire leads on vapor proof light junction box.
11. Re-Install receptacle plate and globe on vapor proof light.
12. To replace the S/S channel, applying pressure with your hand, press down until the cover snaps in place.
13. Re-install threshold
14. Turn power supply on



## 4.3 DOOR SWEEP REPLACEMENT

1. To remove the door, open it past 90 degrees and carefully lift it off the nylon hinge pins. Note the position of the cam faces on the pins. They must be in the proper position so that the door will self-close.
2. Place door on a flat surface, face down.
3. Remove the screws anchoring the old door sweep.
4. Install new sweep by pushing the dart into the groove in the channel. The interior sweep should be at least as wide as the door opening. The length of the exterior sweep should be the same as the width of the door face. Make relief cut-outs at the end of each exterior sweep where it overlaps the magnetic gasket.
5. Replace screws removed in Step 3. See Fig. 20.
6. Reverse the procedure in Step 1 to the reinstall door. Be certain that the nylon cams are in the same position they were in when the door was removed. When properly positioned, the nylon cams will lower the door as it closes, and raise the door as it opens.
7. Be sure that your building floor under the door swing radius is free of any protrusions or sharp objects which may damage the sweep.

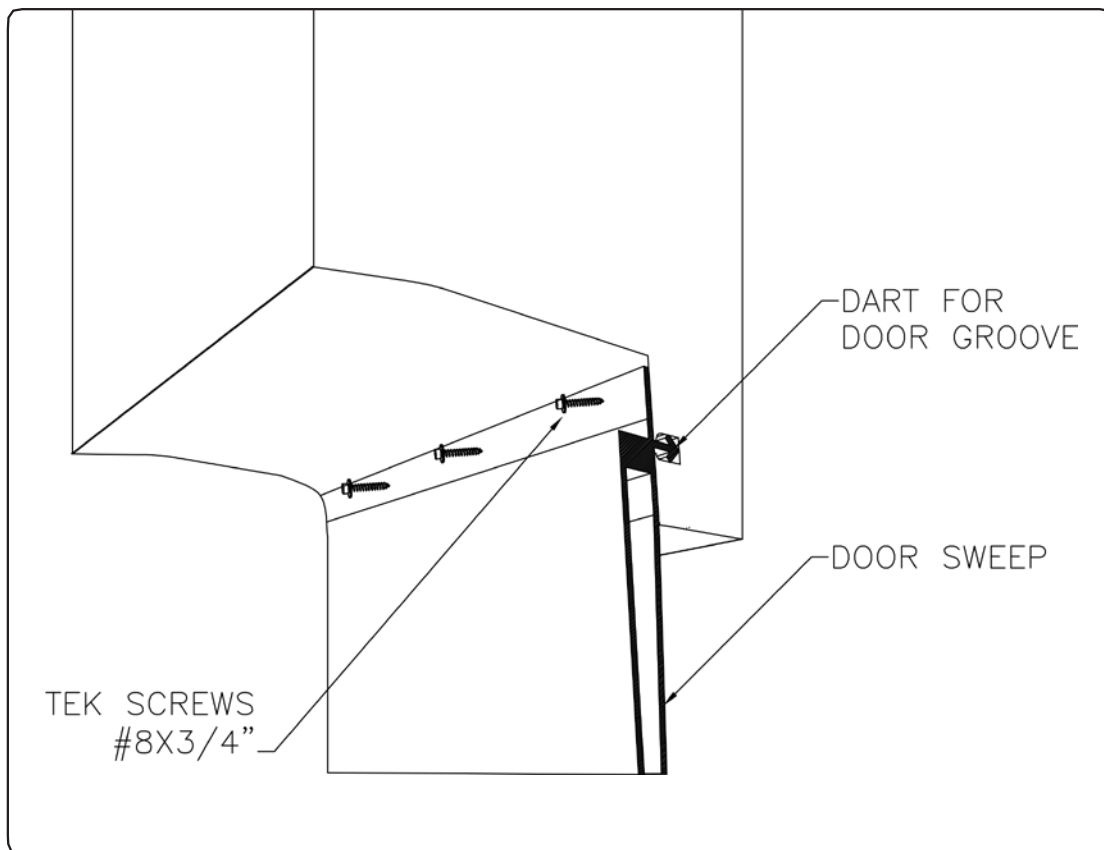

FIG 20. DOOR SWEEP REPLACEMENT

## 4.4 MAGNETIC GASKET REPLACEMENT

1. The door gasket snaps into a narrow channel inside the door's edge and can be removed by pulling it upward starting at the bottom of the door.
2. The new gasket is installed by pushing its dart into the door groove starting at one upper corner. Be sure that the gasket is the right size before attempting to install it. See Fig. 21.

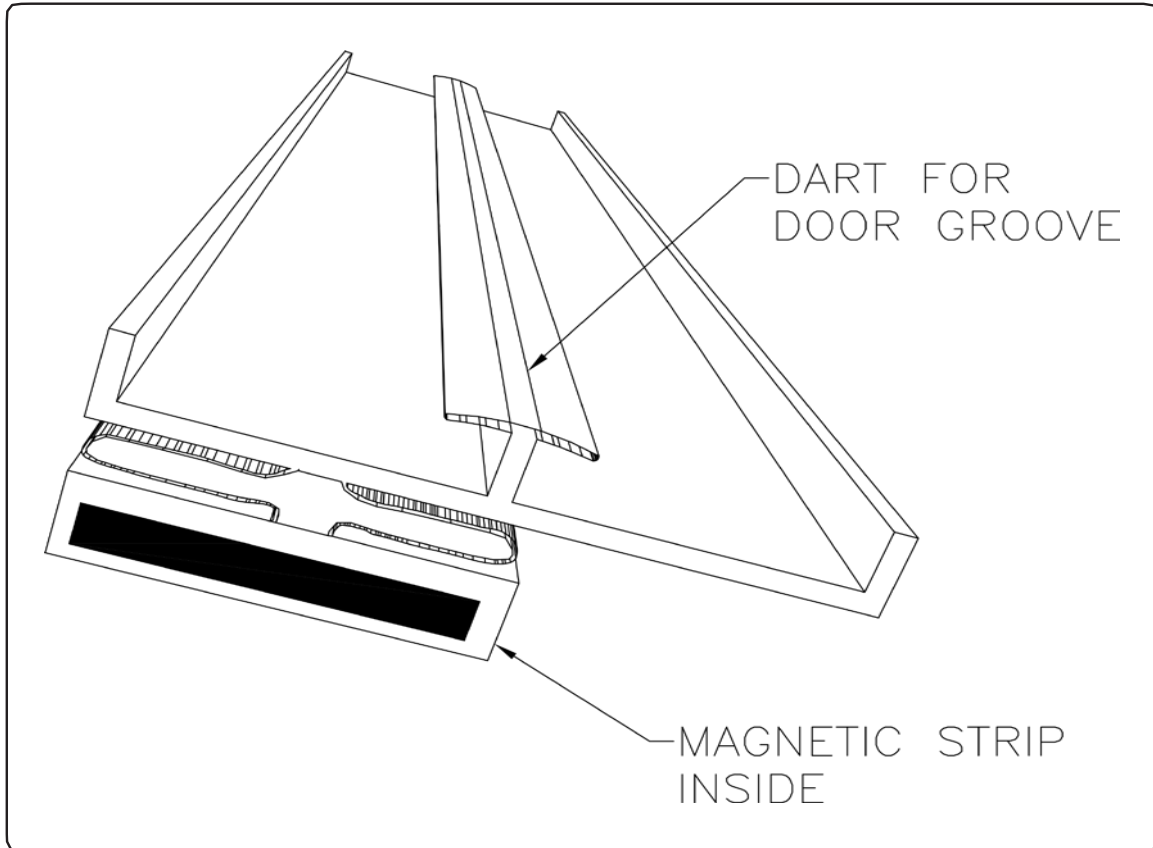

FIG 21. MAGNETIC GASKET REPLACEMENT

## 4.5 THERMOSTAT ADJUSTMENTS

Should temperature requirements change, the thermostat range and set point may be adjusted.

**NOTE:** Some dial analog thermostats are provided with an exterior adjusting knob and some may require removal of the case by loosening the screw at the bottom. In all cases, turning the screw or knob in the center of the temperature dial rotates the dial against the pointer for adjustments of the Set Temperature. It should not be necessary to adjust the differential which should remain at approximately 5 degrees.

**CAUTION:** Do not set a walk-in's thermostat below the walk-in's design temperature or product freezing and/or excessive evaporator coil icing may result. Always have a competent refrigeration technician make any critical adjustments made necessary by changing conditions as mentioned in Section 2.9.3.

## SECTION 5: ELECTRICAL SCHEMATICS

Please visit our online support library or contact us at:

<https://www.arcticwalkins.com/>

## SECTION 6: REPLACEMENT PARTS

For replacement parts please visit us at:

<https://mywalkinparts.com/>



## SECTION 7: WARRANTY

### **IMPORTANT! REGISTRATION REQUIRED!**



REGISTER YOUR WALK-IN ONLINE at <https://www.arcticwalkins.com/>

THE WARRANTY WILL BECOME EFFECTIVE ONLY UPON RECEIPT BY ARCTIC OF THE “FULLY-COMPLETED” WARRANTY REGISTRATION ONLINE FORM.

**See Warranty Terms and Conditions below.** In the event of any problem not covered by these instructions or any perceived defect in material or equipment, please consult our factory or an authorized sales representative. **Arctic will not accept responsibility for the payment of work performed without prior authorization from the factory.**

Parts and compressors under warranty are to be replaced only. In the event that they must be field purchased, Arctic will allow only their factory cost. Consult our customer service department and please refer to the walk-in's job/serial/invoice number in any communication.

### **IMPORTANT WARRANTY INFORMATION**

THE REFRIGERATION SYSTEMS SUPPLIED BY ARCTIC INDUSTRIES ARE COVERED BY THREE WARRANTIES.

TO ACTIVATE THESE WARRANTIES, YOU **MUST** FILL OUT THE WARRANTY REGISTRATION ONLINE. **YOUR WARRANTY IS NOT VALID UNTIL YOU DO.**

YOUR SERVICE TECHNICIAN IS **REQUIRED** TO CALL THE ARCTIC INDUSTRIES CUSTOMER-SERVICE DEPARTMENT PRIOR TO ANY WARRANTY WORK BEING PERFORMED.

IF EMERGENCY WARRANTY SERVICE MUST BE PERFORMED AFTER ARCTIC BUSINESS HOURS, SEND A REASONABLE BILL FOR THE WORK PERFORMED AND ARCTIC WILL REIMBURSE YOU FOR THE WHOLESALE COST OF PARTS AND THE LABOR ON A STRAIGHT TIME BASIS ACCORDING TO THE TERMS OF THE WARRANTY.

#### **1) ONE YEAR REFRIGERATION LABOR WARRANTY:**

ARCTIC INDUSTRIES WARRANTS TO THE ORIGINAL PURCHASER/USER AT THE LOCATION WHERE ORIGINALLY INSTALLED, THE REASONABLE COSTS, STRAIGHT TIME ONLY, ASSOCIATED WITH THE LABOR PORTION OF THE SERVICE BILL FOR 1 YEAR FROM DATE OF INSTALLATION OR UP TO (15) MONTHS FROM THE DATE OF SHIPMENT, WHICHEVER EVENT OCCURS FIRST, WHEN PROPERLY INSTALLED AND OPERATED UNDER NORMAL USE.

THE SELLER'S ONLY LIABILITY UNDER THIS WARRANTY OR OTHERWISE SHALL BE THE REPAIR OR REPLACEMENT (AT SELLER'S OPTION) OF NONCONFORMING GOODS OR PARTS. SELLER ASSUMES NO LIABILITY FOR INCIDENTAL OR CONSEQUENTIAL DAMAGES SUCH AS INJURY TO PERSONS OR PROPERTY, OR LOST PROFITS.

#### **2) ONE YEAR PARTS WARRANTY:**

THIS WARRANTY WILL REPLACE FROM FACTORY INVENTORY OR REIMBURSE FOR REPLACEMENT IN THE FIELD, AT ARCTIC WHOLESALE COST AT ARCTIC'S OPTION, ANY PART THAT PROVES DEFECTIVE. ALL PARTS MUST BE RETURNED TO ARCTIC FOR EVALUATION. ALL RETURNS MUST HAVE PRIOR RETURN AUTHORIZATION FROM ARCTIC.

#### **3) FIVE YEAR LIMITED COMPRESSOR WARRANTY:**

THIS WARRANTY WILL PAY THE COST TO REPLACE THE ACTUAL COMPRESSOR, LESS LABOR FOR A FIVE-YEAR PERIOD. THE LABOR COSTS ARE COVERED DURING THE FIRST YEAR ONLY UNDER THE TERMS OF THE ONE YEAR LABOR WARRANTY.

ARCTIC WARRANTIES DO NOT COVER REFRIGERATION LINES PROVIDED BY YOUR INSTALLER, CONDENSATE LINES PROVIDED BY YOUR PLUMBER OR ELECTRICAL LINES/AND/OR CONNECTIONS PROVIDED BY YOUR ELECTRICIAN. MINOR ADJUSTMENTS, STANDARD MAINTENANCE, DIAGNOSTICS, REFRIGERANT, TORCH CHARGES, SILVER SOLDER, OR TAXES ARE NOT COVERED.

TRAVEL RELATED COSTS ARE LIMITED TO \$35.00

## WARRANTY TERMS AND CONDITIONS

### **One Year Original Equipment Parts Warranty**

Arctic Industries warrants the original purchaser/user at the location where originally installed, for a one-year period from the installation date, the repair or replacement of defective parts at Arctic's option.

This warranty is limited to the repair or replacement of any warranty part, that upon return with Arctic's authorization, and in the judgement of Arctic Industries, proves to be defective.

This warranty applies to all refrigeration, parts, walk-in panels and door parts, originally supplied by Arctic Industries.

This warranty is expressly in lieu of any other warranties, expressed or implied, including any implied warranty of merchantability or fitness for a particular purpose and of all of the liabilities and obligations, on Arctic's part. Under no circumstances shall Arctic Industries be liable to the purchaser or any other party for any special or consequential damages.

This warranty is for all parts supplied by Arctic, and applies only to the continental United States, Virgin Islands and Puerto Rico.

### **One Year Refrigeration Labor Warranty**

Arctic Industries warrants to the original purchaser/user at the location where originally installed, the reasonable costs, straight time only, associated with the labor portion of the service bill for 1 Year from date of installation or up to (15) months from date of shipment, whichever event occurs first, when properly installed and operated under normal use.

The Seller's only liability under this warranty or otherwise shall be the repair or replacement (at Seller's option) of nonconforming goods or parts. Seller assumes no liability for incidental or consequential damages such as injury to persons or property, or lost profits.

This warranty only applies to the labor associated with the repair or replacement of defective warranted parts on the refrigeration system supplied by Arctic Industries. The labor cost is paid for or reimbursed by Arctic only after the defective parts are returned to Arctic, with a return authorization, freight pre-paid, and then following an inspection by Arctic Industries, are found to be defective.

This warranty applies to all refrigeration systems supplied by Arctic Industries. This warranty does not include filed wiring and plumbing. Refrigeration lines not supplied by or contracted for by Arctic, minor service adjustments, maintenance, diagnostics, refrigerant, torch charges, silver solder, or taxes are also excluded. Travel related costs are limited to \$35.

This warranty is expressly in lieu of any other warranties, expressed or implied, including any implied warranty of merchantability or fitness for a particular purpose and of all of the liabilities and obligations, on Arctic's part. Under no circumstances shall Arctic Industries be liable to the purchaser or any other party for any special or consequential damages.

This warranty is for all refrigeration supplied by Arctic, and applies only to the continental United States, Virgin Islands and Puerto Rico.

## **Five Year Limited Compressor Warranty**

Arctic Industries warrants to the original purchaser/user at the location where originally installed, the compressor herein defined to be free from defects in material and factory workmanship, for a period of five (5) years from the date of sale, and if the unit were properly installed, operated, and maintained under normal conditions, Arctic agrees to repair or replace at its option, with similar part or parts, any part or parts of said compressor proved to the satisfaction of the Warrantor to have been defective at time of sale.

The maximum liability of the Warrantor for any one replacement or repair shall be limited to the payment of the Warrantor's sale price to dealers in effect at the time the Warranty is issued. All replacement compressors shall be protected by the installation of a new liquid and suction drier.

Arctic Industries further agrees to extend without charge, for the balance of the above specified Warranty period, similar or like coverage for one (1) additional new or repaired compressor, provided the repair or replacement of the original compressor was made under the terms of this Warranty. The compressor herein warranted shall mean the compressor housing, the motor power unit which drives the compressor, including the compressing mechanism enclosed in said housing, but excludes all external electrical components.

This Warranty shall be void if the compressor identified herein is installed or operated contrary to the manufacturer's instructions, or if identification or serial numbers have been altered, defaced or removed.

This Warranty does not apply to damage to said compressor in transit after sale, nor to damage caused by authorized alterations, fire, accidents, lightning, misuse or abuse, or by any cause other than defects in factory workmanship and materials, nor to any damage or loss of any refrigerant, including any products or property then stored or located within the area being cooled; nor to loss of profits or income due to any malfunctioning of the warranted compressor.

The Warrantor does not assume any liability or costs of labor, freight, or other incidental costs, or for any expenses incurred due to short or reduced supply. Any warranty replacement will be made F.O.B Arctic.

This Warranty is not assignable except only with the prior written consent of the Warrantor. All materials replaced under this Warranty becomes the property of the Warrantor.

All other refrigeration equipment sold by arctic carries a one-year warranty made by the manufacturer and is not warranted in any respect by arctic.

This Warranty is expressly in lieu of any other warranties, expressed or implied, including any implied warranty of merchantability or fitness for a particular purpose and of all of the liabilities and obligations, on Arctic's part. Under no circumstances shall Arctic Industries be liable to the purchaser or any other party for any special or consequential damages.

## **Fifteen Year Panel & Door Warranty**

Arctic Industries warrants to the original purchaser-user, that the walk-in refrigerated rooms and other prefabricated insulated boxes, panels or doors manufactured by the company are free from any defect in material or workmanship under the conditions of normal use and service, provided that it remains in the location where originally installed.

The Company's obligation under this Warranty shall be limited to repairing or replacing at our option, FOB factory, any of the covered parts of said walk-in which proved defective within fifteen (15) years from the date of original installation. All materials replaced under this Warranty become the property of the Warrantor.

This Warranty does not apply to equipment which has been subject to any accident, fire, negligence, alteration, damage in transit, abuse, misuse, or improper installation. This Warranty does not include any labor charge for removal of defective parts or installation of replacement parts or transportation charges to or from our factory. This Warranty does not apply to any equipment sold or supplied by Arctic Industries, but manufactured by others and covered by their separate warranties and not by this Warranty.

This Warranty is expressly in lieu of any other warranties, expressed or implied, including any implied warranty of merchantability or fitness for a particular purpose and of all of the liabilities and obligations, on Arctic's part. Under no circumstances shall Arctic Industries be liable to the purchaser or any other party for any special or consequential damages.

**ARCTIC CUSTOMER SERVICE**

Central and Eastern U.S. (305) 883-3716

Western U.S. (626) 508-0921



**Arctic Industries, LLC.**

Miami, FL

(305) 883-5581

Los Angeles, CA

(626) 508-0920

<http://www.arcticwalkins.com>